

Mail to: P.O. Box 1690, Pleasanton, CA 94566

Ship to: 440 Boulder Court, Suite 100C, Pleasanton, CA 94566

Dynamic Mixer PP97 Plus Parts 2012

0504	Motor brushes (pair)	13.32
0601	Bearing	13.32
0609	Waterproof Seal	15.52
0647	D15 bearing	18.84
0702	Handle screws (3)	0.70
0726	Motor bearing Spring	1.87
0768	Safety button return spring	3.68
0769	M4 washer	1.38
079959	Circular clips	1.87
0830	Rubber Washer	13.16
0835	Fan	116.48
0836	Friction washer	13.43
0842	Grid Blade Protector	163.07
0950	Strain relief bushing	2.33
0950.1	Strain relief bushing	2.33
0965	Switch (115v)	35.35
0972	Capacitor (115v)	13.17
0972.1	Capacitor and filter (230v)	15.25
109913	ID Label (230v)	4.99
109914	ID Label (115v)	4.99
4022	Holder Assembly Screws	3.94
7908.31	Motor armature (115v)	212.18
7912	Motor bearing sleeve	3.52
7933	Fan	8.48
8422	Anti-friction Washer	15.77
8423	Lower Nut for blade	29.99
8429	Double Gear with Washer	112.62
8430	Single Gear & Shaft	117.83
9002	Half handle button side	52.09
9005	Safety button	2.81
9009	Plug (deactivates switch)	2.81
9010	Control lever	12.23
9012	Variable speed control knob	3.79
9013	Variable Speed Control board	89.54
9014	Handle screws (4)	0.62
9015	Motor housing brush holder	70.53
9023	Field spacer screws (2)	3.52
9026	Spacers (4)	15.01
9038	Motor field (115v)	188.60
9053	Variable Speed Control	89.59
9112	Speed control plug	1.92
9143	Ground wire (115v)	8.86
9230a	Whisk 300mm	441.93
9230b	Whisk 400mm	454.11



Mail to: P.O. Box 1690, Pleasanton, CA 94566

Ship to: 440 Boulder Court, Suite 100C, Pleasanton, CA 94566

Dynamic Mixer PP97 Plus Parts

9230c	Whisk 120mm	421.81
9240	casing, bearing seal, tube, lever assembly	179.09
9241	Exit shaft	198.91
9708	Power cord (230v)	28.00
9708.1	Power cord (115v)	28.00
9709	Plate w/ 2 Seals	29.76
9760	Half lower handle w/label (230v)	53.23
9760.1	Half lower handle w/label (115v)	53.23
9761	Lower motor housing	466.83
9762	Exit shaft w/ gear	114.27
9764	Aluminum carter, foot, seals	153.20
9765.1	Complete handle with cord (115v)	150.10
9766	Casing, shaft, bearing seal, ball bearing, rubber ring	150.10

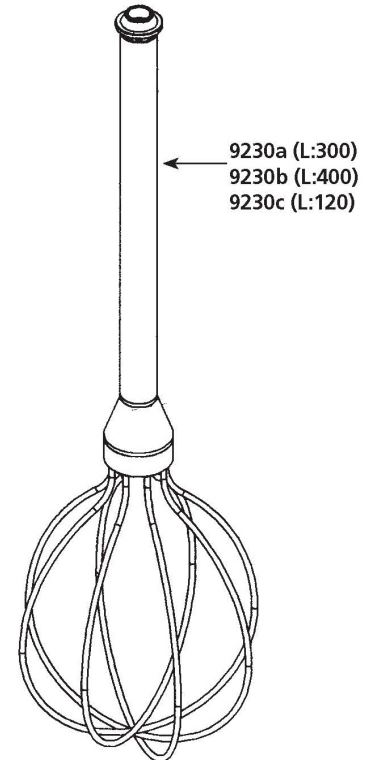
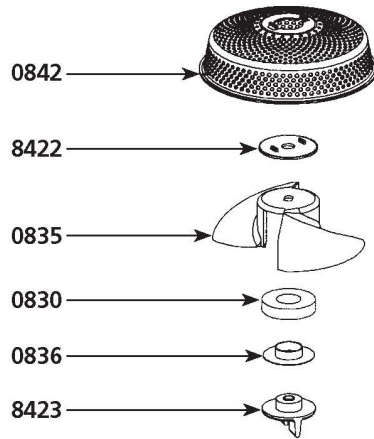
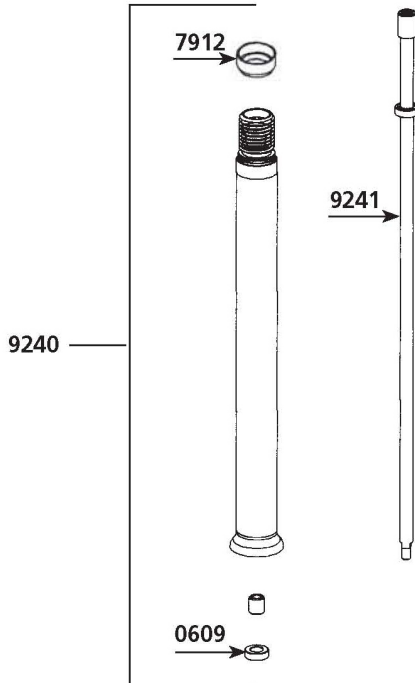
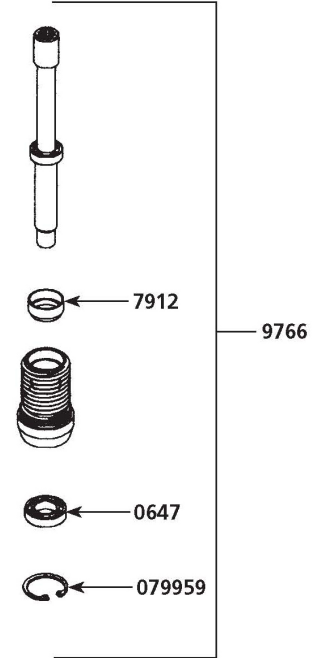

Mail to: P.O. Box 1690, Pleasanton, CA 94566

Ship to: 440 Boulder Court, Suite 100C, Pleasanton, CA 94566

Dynamic Mixer PP97 Plus Parts

