



Dynamic Mixers, Cutters, & Spinners  
Santos Juicers, Cutters, & Grinders  
furi Knives & Sharpeners  
Sales, Parts, & Service

Phone: (925) 417-0617  
Fax: (925) 417-0372  
Email: [Novon2@earthlink.net](mailto:Novon2@earthlink.net)  
[www.DynamicMixerParts.com](http://www.DynamicMixerParts.com)

Mail to: P.O. Box 1690, Pleasanton, CA 94566

Ship to: 440 Boulder Court, Suite 100C, Pleasanton, CA 94566

### Dynamic Mixer MFAP90 / MF90 Parts

0504	Motor brushes (pair)	12.93
0601	Bearing	12.93
0607	Double lip waterproof seal	16.86
0608	Waterproof seal	17.33
0609	Waterproof Seal	15.07
0647	D15 bearing	18.29
0726	Motor bearing Spring	1.82
0744	Pins 3 x 20	2.02
0745	Pin 3 x 14	1.82
0767	Lock button return spring	3.83
0768	Safety button return spring	3.57
079959	Circular clips	1.82
0829	Motor bushing	19.59
0830	Rubber Washer	12.78
0834	Blade	86.90
0836	Friction washer	13.04
0871	Grid	107.74
0880	Wall bracket	7.51
0950	Strain relief bushing	2.26
0950.1	Strain relief bushing	2.26
0965	Switch (115v)	34.32
0970	Capacitor (115v)	19.15
1017	Warning label	4.54
1027	Dynamic Label	11.26
1031	ID Label (115v)	4.73
1186	Support and Lower Ring	20.64
7903	Spacer screws (4)	4.19
7910	Emulsifying blade	54.53
7916	Lower bearing assembly	32.42
7917	Cutter blade	36.13
7933	Fan	8.23
7950	Lower bearing screws (3)	1.06
8317	Spacers screws (4)	4.19
8422	Anti-friction Washer	15.31
8423	Lower Nut for blade	29.12
8429	Double Gear with Washer	109.34
8430	Single Gear & Shaft	114.40
8612	Holder + plastic ejector	58.94
8613	Plastic ejectors (pair)	25.16
8615	Whip only (pair)	134.39
9000.1	Complete Handle (115v)	219.73
9001	Half Handle Label Side	51.86
9001.1	Half Handle Label Side	51.86



Dynamic Mixers, Cutters, & Spinners  
Santos Juicers, Cutters, & Grinders  
fűri Knives & Sharpeners  
Sales, Parts, & Service

Phone: (925) 417-0617  
Fax: (925) 417-0372  
Email: [Novon2@earthlink.net](mailto:Novon2@earthlink.net)  
[www.DynamicMixerParts.com](http://www.DynamicMixerParts.com)

Mail to: P.O. Box 1690, Pleasanton, CA 94566

Ship to: 440 Boulder Court, Suite 100C, Pleasanton, CA 94566

### Dynamic Mixer MFAP90 / MF90 Parts

9002	Half handle button side	50.57
9004	Kit-Shaft lower bearing	154.63
9005	Safety button	2.73
9007	Lock button	2.62
9008.11	Motor (115v)	206.00
9008.12	Motor (230v)	206.00
9009	Plug (deactivates switch)	2.73
9010	Control lever	11.87
9012	Variable speed control	3.68
9013	Variable Speed Control	86.93
9014	Handle screws (4)	0.60
9015	Motor housing brush holder	68.48
9023	Field spacer screws (2)	3.42
9024	Lower aluminum housing	122.10
9025	Motor Bearing Sleeve	3.95
9026	Spacers (4)	14.57
9028	Coupler for armature	8.60
9031	Shaft	114.40
9034	Reduction gear assembly	266.76
9038	Motor field (115v)	183.11
9040	Power cord (2 wire) (1	21.22
9046	Lower casing w/o middle	221.17
9048	Central double gear &am	93.86
9049	Single gear (2)	76.30
9050	Upper plastic casing	77.85
9051	Coupler for armature	13.67
9053	Variable Speed Control	86.98
9054	Reducing Casing	76.68
9055	Equipped upper shaft	64.83
9057	Complete upper casing	101.15
9060	Foot Assembly	286.60
9062	Main Shaft	146.48
9064	Reduction Casing Screws	3.55
9065	Upper Plastic Casing	101.15
9143	Ground wire (115v)	8.60
9230a	Whisk 300mm	429.06
9230b	Whisk 400mm	440.88
9230c	Whisk 120mm	409.52
9231	Main shaft	271.39
9232	Lower carter	160.37
9233	Handle and casing	73.41
9250	Complete reduction box w/o bowl, wisk, or handle	524.94
9901	Foot Assembly	189.50

Mail to: P.O. Box 1690, Pleasanton, CA 94566

Ship to: 440 Boulder Court, Suite 100C, Pleasanton, CA 94566

Dynamic Mixer MFAP90 / MF90 Parts

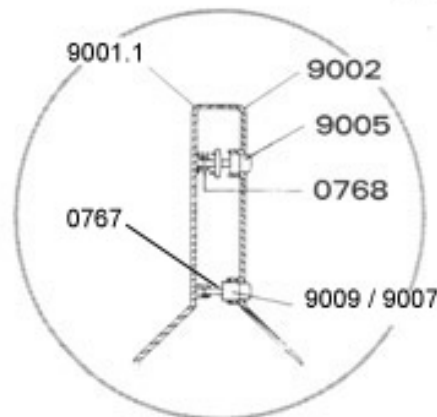
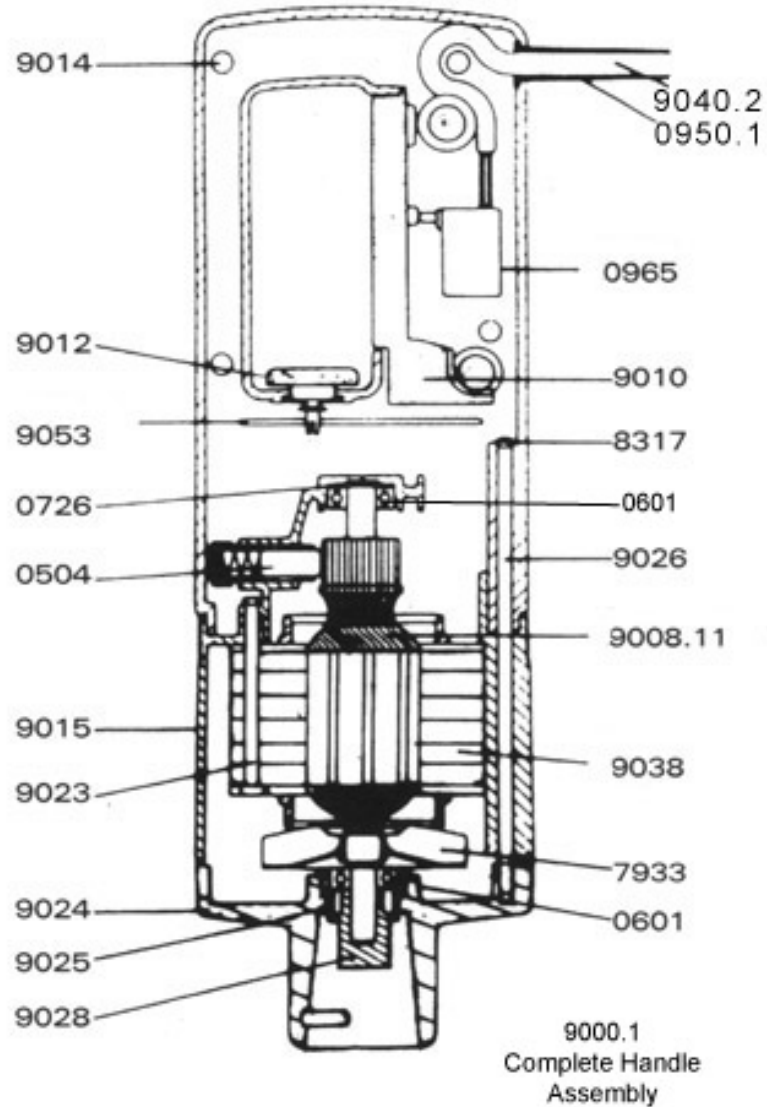

Mail to: P.O. Box 1690, Pleasanton, CA 94566

Ship to: 440 Boulder Court, Suite 100C, Pleasanton, CA 94566

### Dynamic Mixer MFAP90 / MF90 Parts

